

Highly Flexible Couplings ELPEX-B Series



10/2	Overview
10/2	Benefits
10/2	Application
10/2	Design
10/4	Technical data
10/5	Type EBWN
10/5	Selection and ordering data
10/6	Type EBWT
10/6	Selection and ordering data
10/8	Type EBWZ
10/8	Selection and ordering data
10/10	Spare and wear parts
10/10	Selection and ordering data

FLENDER Standard Couplings

Highly Flexible Couplings - ELPEX-B Series

General information

Overview



ELPEX-B couplings are highly flexible and free of torsional backlash. Because of their low torsional stiffness and damping capacity, ELPEX-B couplings are especially suitable for coupling machines with a highly non uniform torque pattern. ELPEX-B couplings are also suitable for connecting machines with high shaft misalignment.

Standard ELPEX-B coupling types are designed as shaft-shaft connections. Application-related types can be manufactured on request.

Benefits

The ELPEX-B coupling is suitable for horizontal and vertical mounting positions or mounting positions at any required angle.

The elastic tire is slit at the circumference and can be changed without having to move the coupled machines.

The elastic tire is fitted without backlash and gives the coupling linear torsional stiffness, thus the torsional rigidity remains constant as the load on the coupling increases.

The ELPEX-B coupling is especially suitable for reversing operation or operation with changing directions of load.

The coupling parts can be arranged as required on the shaft ends to be connected.

If the elastic tire is irreparably damaged or worn, the metal parts can rotate freely against one another because they are not in contact with one another.

Application

The ELPEX-B coupling is available as a catalog standard in 15 sizes with a rated torque of between 24 Nm and 14500 Nm. The coupling can be fitted with elastic tires made of natural rubber for ambient temperatures of -50 °C to $+50\text{ °C}$ and with elastic

tires made of chloroprene rubber for -15 °C to $+70\text{ °C}$. The chloroprene rubber tire is marked FRAS, "Fire-resistant and Anti-static".

Design

The ELPEX-B coupling's transmission characteristic is determined essentially by the elastic tire. The elastic tire is manufactured from a natural rubber or a chloroprene rubber mixture with a multiply fabric insert. The elastic tire is fastened to the hubs with bolts and two clamping rings.

In type EBWT, the shaft-hub connection is achieved with Taper clamping bushes, in type EBWN with finish-drilled hubs and parallel keys. The type EBWZ connects the machine shafts additionally via a detachable adapter.

Materials

Metal part materials

EN-GJL-250 grey cast iron or steel of quality $R_e > 300\text{ N/mm}^2$.

Elastic tire material

Material	Hardness	Identification	Ambient temperature
Natural rubber	70 ShoreA	048	-50 °C to $+50\text{ °C}$
Chloroprene rubber	70 ShoreA	068 FRAS	-15 °C to $+70\text{ °C}$

FLENDER Standard Couplings

Highly Flexible Couplings - ELPEX-B Series

General information

ELPEX-B coupling types

Type	Description
EBWN	Coupling as a shaft-shaft connection with drilled and grooved hubs
EBWT	Coupling as a shaft-shaft connection with Taper clamping bushes
EBWZ	Coupling as shaft-shaft connection with detachable adapter

Further application-specific coupling types are available; dimension sheets for and information on these are available on request.

The coupling types set up for shaft-hub connections with Taper clamping bushes are designated as follows:

- Variant A: Coupling with part 3 – part 3
- Variant B: Coupling with part 4 – part 4
- Variant AB: Coupling with part 3 – part 4

In the case of part 3, the Taper clamping bush is screwed in from the shaft end face side. The coupling half must be fitted before the machines to be connected are pushed together.

In the case of part 4, the Taper clamping bush is screwed in from the machine-housing side. If there is insufficient room, the Taper clamping bushes cannot be fitted from this side. Besides fitting space for the Taper clamping bush bolts, space for the fitting tool (offset screwdriver) must be taken into account.

In the case of coupling type EBWT, part 3 and part 4 can be combined as required. Furthermore, the variant with a Taper clamping bush can be combined with the finish-drilled hub.



Unfitted coupling

The elastic tire can simply be slipped over the hub parts. The elastic tire is held firmly in place by fitting the clamping ring. The connection transmits the torque by frictional engagement.



Fitted coupling, shown without connecting shafts.



Fitted elastic tire

FLENDER Standard Couplings

Highly Flexible Couplings - ELPEX-B Series

General information

Technical data

Power ratings

Size	Rated torque	Maximum torque	Overload torque	Fatigue torque	Maximum speed	Dynamic torsional stiffness for 100 % load	Permitted shaft misalignment at speed $n = 1500 \text{ rpm}^1)$		
	T_{KN} Nm	T_{Kmax} Nm	T_{KOL} Nm	T_{KW} Nm	n_{Kmax} rpm	C_{Tdyn} Nm/rad	ΔK_a mm	ΔK_r mm	ΔK_w Degrees
105	24	48	72	7	4500	285	1.3	1.1	4
135	66	132	200	20	4500	745	1.7	1.3	4
165	125	250	375	38	4000	1500	2.0	1.6	4
190	250	500	750	75	3600	2350	2.3	1.9	4
210	380	760	1140	114	3100	3600	2.6	2.1	4
235	500	1000	1500	150	3000	5200	3.0	2.4	4
255	680	1360	2040	204	2600	7200	3.3	2.6	4
280	880	1760	2640	264	2300	10000	3.7	2.9	4
315	1350	2700	4050	405	2050	17000	4.0	3.2	4
360	2350	4700	7050	705	1800	28000	4.6	3.7	4
400	3800	7600	11400	1140	1600	44500	5.3	4.2	4
470	6300	12600	18900	1890	1500	78500	6.0	4.8	4
510	9300	18600	27900	2790	1300	110000	6.6	5.3	4
560	11500	23000	34500	3450	1100	160000	7.3	5.8	4
630	14500	29000	43500	4350	1000	200000	8.2	6.6	4

Torsional stiffness and damping

The damping coefficient is $\Psi = 0.9$

The technical data for the elastic tires made of natural rubber and chloroprene rubber are virtually identical.

Torsional stiffness depends on the ambient temperature and the frequency and amplitude of the torsional vibration excitation. More precise torsional stiffness and damping parameters on request.

Permitted shaft misalignment

The permitted shaft misalignment depends on the operating speed. As the speed increases, lower shaft misalignment values are permitted. The correction factors for different speeds are specified in the following table.

The maximum speed for the respective coupling size must be observed!

$$\Delta K_{perm} = \Delta K_{1500} \cdot FKV$$

	Speed in rpm			
	500	1000	1500	3000
Correction factor FKV	1.6	1.25	1.0	0.70

The restorative force (including in the axial direction) depends on speed, system torque and shaft misalignment. Restorative forces on request.

¹⁾ The maximum speed of the respective type must be noted. For further information on permissible shaft misalignment, please see the operating instructions.

FLENDER Standard Couplings Highly Flexible Couplings - ELPEX-B Series

Type EBWN

Selection and ordering data

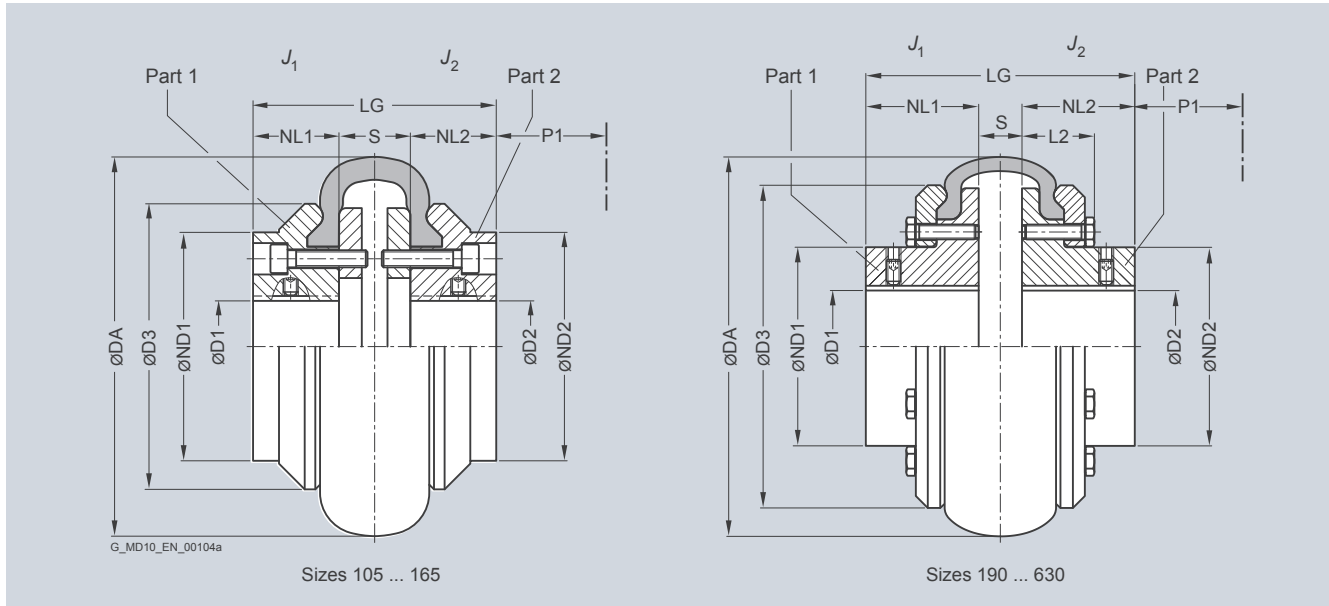

Size	Rated torque T_{KN} Nm	Dimensions in mm										Mass moment of inertia J_1/J_2 kgm ²	Product code Order codes for bore diameters and tolerances are specified in catalog section 3	Weight m kg
		Bore with keyway to DIN 6885-1 D1, D2 min. max.		DA	ND1 ND2	NL1 NL2	D3	L2	S	LG				
105	24	-	30	104	70	30	82	-	22	82	0.0011	2LC0210-0AA	■ ■ -0AA0	2.2
135	66	-	38	134	80	40	100	-	25	105	0.0025	2LC0210-1AA	■ ■ -0AA0	3.6
165	125	-	45	165	70	50	125	-	33	133	0.0056	2LC0210-2AA	■ ■ -0AA0	5.4
190	250	-	50	187	80	55	145	39	23	133	0.0095	2LC0210-3AA	■ ■ -0AA0	6.9
210	380	-	60	211	98	65	168	42	25	155	0.020	2LC0210-4AA	■ ■ -0AA0	11
235	500	-	70	235	112	70	188	47	27	167	0.023	2LC0210-5AA	■ ■ -0AA0	14.8
255	680	-	80	254	130	75	216	49	27	177	0.060	2LC0210-6AA	■ ■ -0AA0	20
280	880	-	90	280	145	80	233	50	25	185	0.083	2LC0210-7AA	■ ■ -0AA0	24.5
315	1350	-	90	314	150	90	264	53	29	209	0.129	2LC0210-8AA	■ ■ -0AA0	35
360	2350	-	125	359	200	100	311	57	32	232	0.32	2LC0211-0AA	■ ■ -0AA0	54
400	3800	-	135	402	216	125	345	63	30	280	0.55	2LC0211-1AA	■ ■ -0AA0	78
470	6300	-	160	470	260	140	398	71	46	326	1.12	2LC0211-2AA	■ ■ -0AA0	120
510	9300	-	140	508	250	150	429	79	48	348	1.6	2LC0211-3AA	■ ■ -0AA0	146
		140	180	290							1.7	2LC0211-3AA	■ ■ -0AA0	154
560	11500	-	140	562	250	165	474	91	55	385	2.5	2LC0211-4AA	■ ■ -0AA0	200
		140	180	300							2.7	2LC0211-4AA	■ ■ -0AA0	206
630	14500	80	140	629	250	195	532	96	59	449	4.1	2LC0211-5AA	■ ■ -0AA0	258
		140	180	300							4.4	2LC0211-5AA	■ ■ -0AA0	265
$\varnothing D1$:		<ul style="list-style-type: none"> Without finished bore – Without order codes Without finished bore from size 510 for 2nd diameter range D1 – Without order codes With finished bore – With order codes for diameter and tolerance (product code without -Z) 										1	2	
$\varnothing D2$:		<ul style="list-style-type: none"> Without finished bore – Without order codes Without finished bore from size 510 for 2nd diameter range D2 – Without order codes With finished bore – With order codes for diameter and tolerance (product code without -Z) 										1	2	

Weight and mass moments of inertia apply to maximum bore diameters.

The product code applies to elastic tires made of natural rubber.

Product code with **-Z** and order code **K01** for variant of the elastic tire made of chloroprene rubber.

P1 = fitting space for offset screwdriver and ejector bolt for dismounting the Taper clamping bush. For dismounting the elastic tire on sizes 105 to 165, a fitting space of P1 = 35 mm must be provided for the offset screwdriver. Sizes 190 to 630 require P1 = 35 mm of fitting space to undo the clamping ring bolts.

Ordering example:

ELPEX-B EBWN coupling, size 210,
Part 1: Bore 40H7 mm, keyway to DIN 6885-1 and set screw,
Part 2: Bore 45H7 mm, keyway to DIN 6885-1 and set screw.

Product code:
2LC0210-4AA99-0AA0
L0W+M1A

FLENDER Standard Couplings

Highly Flexible Couplings - ELPEX-B Series

Type EBWT

Selection and ordering data

Sizes 105 ... 165

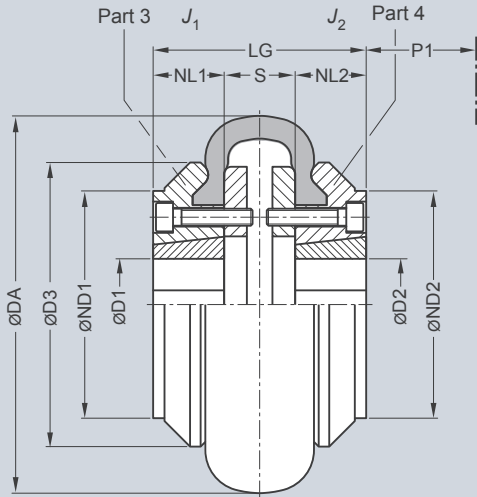

Variant AB

Sizes 190 ... 560

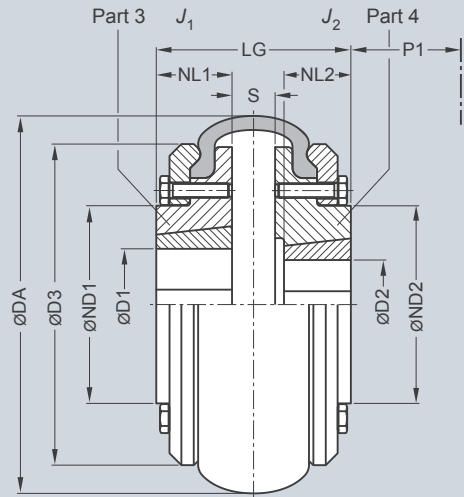

Variant AB

Sizes 105 ... 165

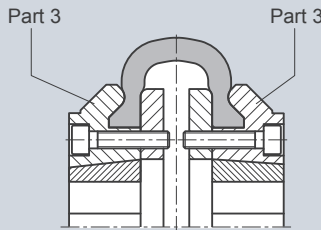

Variant A

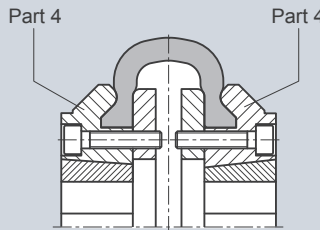

Variant B

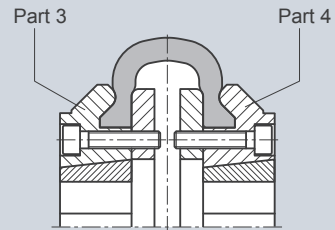

Variant AB

Sizes 190 ... 560

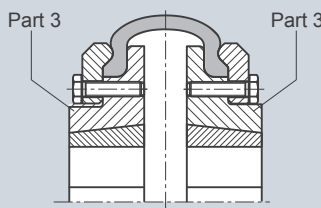

Variant A

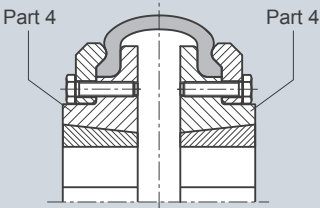

Variant B

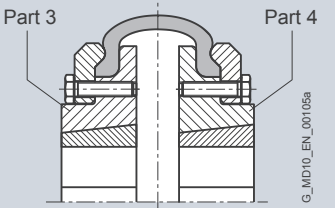

Variant AB

G_MDI0_EN_00105a

Part 3: Screw connection for Taper clamping bush from the shaft end face side
 Part 4: Screw connection for Taper clamping bush from the machine-housing side

FLENDER Standard Couplings

Highly Flexible Couplings - ELPEX-B Series

Type EBWT

Size	Rated torque T_{KN} Nm	Part no.	Taper clamp- ing bush Size	Dimensions in mm								Mass moment of inertia J_1/J_2 kgm ²	Product code Order codes for bore diameters and tolerances are specified in catalog section 3	Weight m kg
				Bore with keyway to DIN 6885-1		DA	ND1/ND2	NL1/NL2	D3	S	LG			
				min.	max.									
105	24	3	1008	10	25	104	-	22	82	22	66	0.0009	2LC0210-0A ■■■-0AA0	1.8
		4												
135	66	3	1210	11	32	134	80	25	100	25	75	0.0019	2LC0210-1A ■■■-0AA0	2.4
		4												
165	125	3	1610	14	42	165	103	25	125	33	83	0.0049	2LC0210-2A ■■■-0AA0	4
		4												
190	250	3	2012	14	50	187	80	32	145	23	87	0.0085	2LC0210-3A ■■■-0AA0	5.4
		4	1610	14	42			25						
210	380	3	2517	16	60	211	98	45	168	25	115	0.017	2LC0210-4A ■■■-0AA0	8
		4	2012	14	50			32						
235	500	3	2517	16	60	235	108	45	188	27	119	0.019	2LC0210-5A ■■■-0AA0	12
		4												
255	680	3	3020	25	75	254	120	51	216	27	129	0.050	2LC0210-6A ■■■-0AA0	14
		4	2517	16	60			113						
280	880	3	3020	25	75	280	146	51	233	25	129	0.075	2LC0210-7A ■■■-0AA0	22
		4												
315	1350	3	3525	35	90	314	140	65	264	29	161	0.11	2LC0210-8A ■■■-0AA0	23
		4	3020	25	75			51						
360	2350	3	3525	35	90	359	178	65	311	32	162	0.26	2LC0211-0A ■■■-0AA0	38
		4												
400	3800	3	4030	40	100	402	197	77	345	30	184	0.44	2LC0211-1A ■■■-0AA0	54
		4												
470	6300	3	4535	55	110	470	205	89	398	46	224	0.8	2LC0211-2A ■■■-0AA0	72
		4												
510	9300	3	4535	55	110	508	200	89	429	48	226	1.5	2LC0211-3A ■■■-0AA0	120
		4												
560	11500	3	5040	70	125	562	222	102	474	55	259	2.0	2LC0211-4A ■■■-0AA0	120
		4												

Variant:

- A
- B
- AB

B
C
D

∅D1: • Without finished bore – Without order codes

- With finished bore – With order codes for diameter and tolerance (product code without **-Z**)

1
9

∅D2: • Without finished bore – Without order codes

- With finished bore – With order codes for diameter and tolerance (product code without **-Z**)

1
9

Weights and mass moments of inertia apply to couplings with Taper clamping bushes with maximum bore diameter.

The product code applies to elastic tires made of natural rubber.

Product code with **-Z** and order code **K01** for variant of the elastic tire made of chloroprene rubber.

P1 = fitting space for offset screwdriver and ejector bolt for dismounting the Taper clamping bush. For dismounting the elastic tire on sizes 105 to 165, a fitting space of P1 = 35 mm must be provided for the offset screwdriver. Sizes 190 to 630 require P1 = 35 mm of fitting space to undo the clamping ring bolts.

Taper clamping bush size 1008 and bores diameters 24 mm and 25 mm with shallow keyway.

Taper clamping bush size 1610 and bores diameter 42 mm with shallow keyway. See catalog section 14.

Ordering example:

ELPEX-B EBWT coupling, size 210,
variant AB, including Taper bushes,
Part 3: with Taper clamping bush, bore 60 mm;
Part 4: with Taper clamping bush, bore 40 mm.

Product code:

2LC0210-4AD99-0AA0
L1E+MOW

FLENDER Standard Couplings

Highly Flexible Couplings - ELPEX-B Series

Type EBWZ

Selection and ordering data

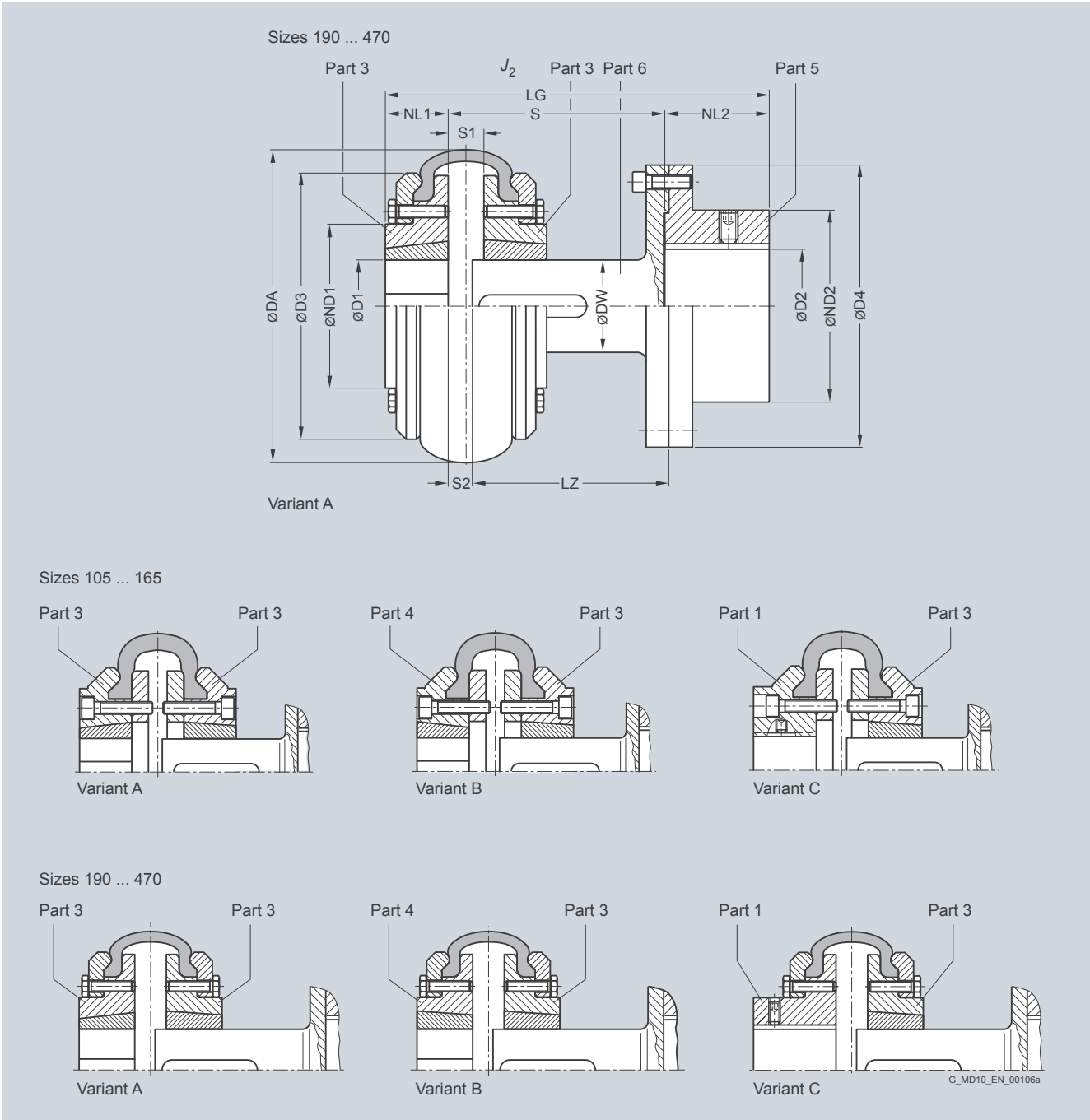

Part 3: Screw connection for Taper clamping bush from the shaft end face side
 Part 4: Screw connection for Taper clamping bush from the machine-housing side

FLENDER Standard Couplings

Highly Flexible Couplings - ELPEX-B Series

Type EBWZ

Size	Rated torque T_{KN} Nm	Dimensions in mm											Mass moment of inertia J_2 kgm ²	Product code Order codes for bore diameters and tolerances are specified in catalog section 3	Weight m kg		
		Bore with keyway to DIN 6885-1		DA	ND2	D4	DW	NL2	LZ	S	S1	S2					
		D2 min.	D2 max.							min.	max.	min.					
105	24	–	42	104	70	95	25	45	96	100	116	22	6	0.0027	2LC0210-0A ■■■■-0A ■ 0	3.3	
									133	140	156						
135	66	–	55	134	90	125	32	50	93	100	116	25	9	0.0085	2LC0210-1A ■■■■-0A ■ 0	5.4	
									133	140	156						
165	125	–	55	165	90	125	32	50	93	100	124	33	9	0.012	2LC0210-2A ■■■■-0A ■ 0	6.2	
									133	140	164						
190	250	–	75	187	125	180	48	80	93.5	100	114	23	9	0.046	2LC0210-3A ■■■■-0A ■ 0	16.0	
									133.5	140	154						
									173.5	180	194						
210	380	–	75	211	125	180	48	80	133.5	140	156	25	9	0.053	2LC0210-4A ■■■■-0A ■ 0	17	
									173.5	180	196						
235	500	–	75	235	125	180	48	80	133.5	140	158	27	9	0.056	2LC0210-5A ■■■■-0A ■ 0	25	
									173.5	180	198						
255	680	–	90	254	150	225	60	100	133.5	140	158	27	9	0.15	2LC0210-6A ■■■■-0A ■ 0	29	
									173.5	180	198						
280	880	–	90	280	150	225	60	100	133.5	140	156	25	9	0.17	2LC0210-7A ■■■■-0A ■ 0	33	
									173.5	180	196						
315	1350	46	100	314	165	250	80	110	134.5	140	160	29	9	0.28	2LC0210-8A ■■■■-0A ■ 0	40	
									174.5	180	200						
360	2350	46	100	359	165	250	80	110	134.5	140	163	32	9	0.43	2LC0211-0A ■■■■-0A ■ 0	48	
									174.5	180	203						
400	3800	51	110	402	180	280	90	120	223.5	200	220	30	10	0.88	2LC0211-1A ■■■■-0A E 0	73	
470	6300	51	120	470	200	315	100	140	207.5	250	286	46	10	0.97	2LC0211-2A ■■■■-0A E 0	104	
Variant:	• A															G	
	• B															H	
	• C															J	
∅D1:	• Without finished bore (for variant C only) – Without order codes															1	
	• With finished bore/Taper clamping bush – With order codes for diameter and tolerance in the case of finished bore (product code without -Z)															9	
∅D2:	• Without finished bore – Without order codes															1	
	• With finished bore – With order codes for diameter and tolerance (product code without -Z)															9	
S min.	100 mm															A	
	140 mm															B	
	180 mm															C	

Dimensions D1, ND1, NL1, J1 and fitting space for dismounting elastic tire and Taper clamping bush, see types EBWN or EBWT.

The product code applies to elastic tires made of natural rubber.

Product code with **-Z** and order code **K01** for variant of the elastic tire made of chloroprene rubber.

Mass moment of inertia J_2 and weight m as total of part 3, part 5 and part 6 with maximum bore diameter.

Ordering example:

ELPEX-B EBWZ coupling, size 360, variant C, for fitting length $S_{min} = 190$ mm, Part 1: Bore 65H7 mm, keyway to DIN 6885-1 and set screw, Part 5: Bore 70H7 mm, keyway to DIN 6885-1 and set screw

Product code:

2LC0211-0AJ99-0AC0
L1F+M1G

10

FLENDER Standard Couplings

Highly Flexible Couplings - ELPEX-B Series

Spare and wear parts

Selection and ordering data

The elastic tires are wear parts. The service life depends on the operating conditions.

Size	Product code	Weight	
	Natural rubber Identification 048	kg	Chloroprene rubber Identification 068 FRAS
			kg
105	2LC0210-0WA00-0AA0	0.1	2LC0210-0WA00-0AA0-Z K01
135	2LC0210-1WA00-0AA0	0.2	2LC0210-1WA00-0AA0-Z K01
165	2LC0210-2WA00-0AA0	0.4	2LC0210-2WA00-0AA0-Z K01
190	2LC0210-3WA00-0AA0	0.5	2LC0210-3WA00-0AA0-Z K01
210	2LC0210-4WA00-0AA0	0.8	2LC0210-4WA00-0AA0-Z K01
235	2LC0210-5WA00-0AA0	1.0	2LC0210-5WA00-0AA0-Z K01
255	2LC0210-6WA00-0AA0	1.2	2LC0210-6WA00-0AA0-Z K01
280	2LC0210-7WA00-0AA0	1.4	2LC0210-7WA00-0AA0-Z K01
315	2LC0210-8WA00-0AA0	2.6	2LC0210-8WA00-0AA0-Z K01
360	2LC0211-0WA00-0AA0	2.9	2LC0211-0WA00-0AA0-Z K01
400	2LC0211-1WA00-0AA0	3.1	2LC0211-1WA00-0AA0-Z K01
470	2LC0211-2WA00-0AA0	5.3	2LC0211-2WA00-0AA0-Z K01
510	2LC0211-3WA00-0AA0	7.8	2LC0211-3WA00-0AA0-Z K01
560	2LC0211-4WA00-0AA0	10.8	2LC0211-4WA00-0AA0-Z K01
630	2LC0211-5WA00-0AA0	12.4	2LC0211-5WA00-0AA0-Z K01

Highly Flexible Couplings ELPEX-S Series

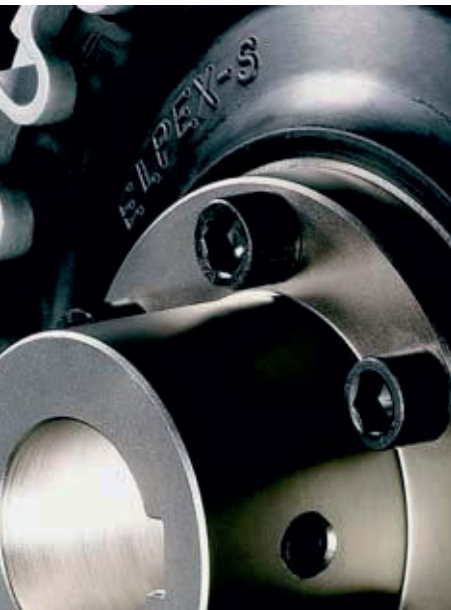

11/2	Overview
11/2	Benefits
11/2	Application
11/2	Design
11/4	Function
11/4	Configuration
11/6	Technical data
11/9	Type ESN
11/9	Selection and ordering data
11/10	Type ESD
11/10	Selection and ordering data
11/11	Type ESNR
11/11	Selection and ordering data
11/12	Type ESDR
11/12	Selection and ordering data
11/13	Types ESNW and ESDW
11/13	Selection and ordering data
11/14	Type EST
11/14	Selection and ordering data
11/15	Spare and wear parts
11/15	Selection and ordering data

FLENDER Standard Couplings

Highly Flexible Couplings - ELPEX-S Series

General information

Overview



Coupling suitable for potentially explosive environments. Complies with Directive 94/9/EC for:

CE Ex II 2 G T3 D160 °C X

CE Ex II 2 G T3 D120 °C X

ELPEX-S couplings are highly torsionally flexible and because of their low torsional stiffness and damping capacity are especially suitable for coupling machines with a highly non uniform torque pattern.

Standard ELPEX-S coupling types are designed as flange-shaft-connections or shaft-shaft connections. Application-related types can be implemented on request.

Benefits

The ELPEX-S coupling is suitable for horizontal and vertical mounting positions or mounting at any required angle. The coupling parts can be arranged as required on the shafts to be connected.

ELPEX-S couplings are especially suitable for reversing operation or operation with changing directions of load.

The rubber disk elements are fitted virtually without backlash and give the coupling linear torsional stiffness, i.e. the torsion stiffness remains constant even when the load on the coupling increases.

There are 4 different rubber element versions with different grades of torsional stiffness available for each size from stock.

On certain types the flexible rings can be changed without having to move the coupled machines.

If substantial overload occurs, the rubber disk element of the coupling is irreparably damaged, the coupling throws the load and thus limits the overload for particular operating conditions. The coupling can be inserted and fitted blind e.g. in a bell housing.

There are outer flanges with different connection dimensions available for each coupling size.

Application

The ELPEX-S coupling is available as a catalog standard in 12 sizes with rated torques of between 330 Nm and 63000 Nm.

The coupling is suitable for ambient temperatures of between -40 °C and +120 °C.

The ELPEX-S coupling is frequently used for diesel motor drives or reciprocating compressor drives. Because the different rubber versions enable the torsional stiffness to be adjusted to meet requirements, the coupling is also suitable for drives which require a specific and preferably precalculated torsional vibration behavior setting.

Design

The rubber disk element is vulcanized onto a flange on the inside diameter. The flange can mount e.g. a Taper clamping bush or a hub. On its outer diameter the rubber disk element has driving teeth, which are inserted into the outer flange. The torque is transmitted positively between the rubber disk element and the outer flange.

In the type for shaft-shaft connection the outer flange is screwed to a flange hub mounted on a machine shaft.

Materials

	Type EST	Types ESN. and ESD.
Rubber disk element	Grey cast iron EN-GJL-250/elastomer	Spheroidal graphite cast iron EN-GJL-400/elastomer
Hubs, part 1, part 2	Steel	Steel
Outer flange	Cast aluminum AlZnSi108. Sizes 680 and 770 of spheroidal graphite cast iron EN-GJS-500	Cast aluminum AlZnSi108. Sizes 680 and 770 of spheroidal graphite cast iron EN-GJS-500

Steel of quality Rm >450 N/mm²

Elastomer materials of the rubber disk element

Material / description	Shore hardness A	Identification	Ambient temperature
Natural-synthetic rubber mixture	50 ° ... 55 °	WN	-40 °C ... +80 °C
Natural-synthetic rubber mixture	60 ° ... 65 °	NN	-40 °C ... +80 °C
Natural-synthetic rubber mixture	70 ° ... 75 °	SN	-40 °C ... +80 °C
Silicone rubber	55 ° ... 65 °	NX	-40 °C ... +120 °C

ELPEX-S coupling types

Type	Description
ESN	Coupling with hub, long or short version
ESD	Coupling with hub, with two rubber disk elements
ESNR	Coupling with hub, rubber disk element radially dismountable
ESDR	Coupling with hub with two rubber disk elements; rubber disk elements radially dismountable
ESNW	Coupling designed as a shaft-shaft connection with a rubber disk element; rubber disk element radially dismountable
ESDW	Coupling designed as a shaft-shaft connection with two rubber disk elements; rubber disk element radially dismountable
EST	Coupling suitable for mounting a Taper clamping bush

FLENDER Standard Couplings Highly Flexible Couplings - ELPEX-S Series

General information

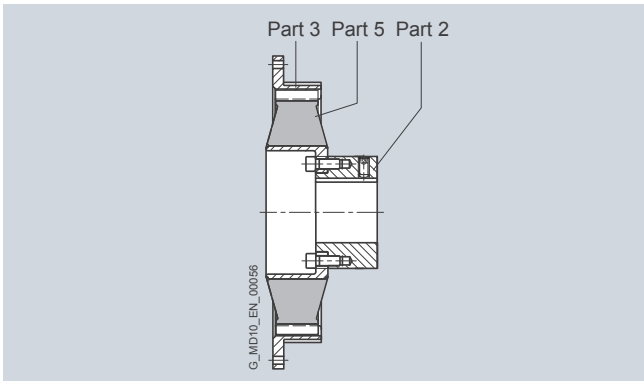

Type **ESN** – long version

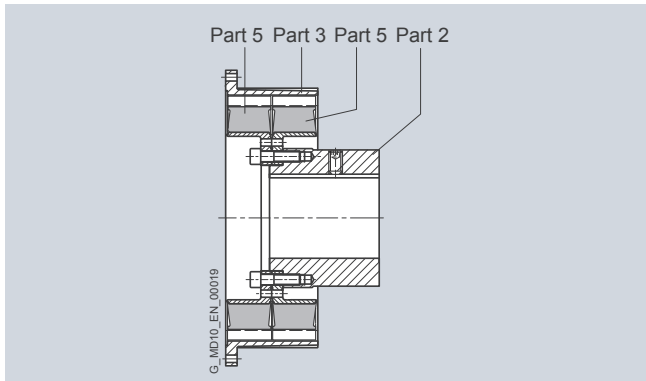

Type **ESD**

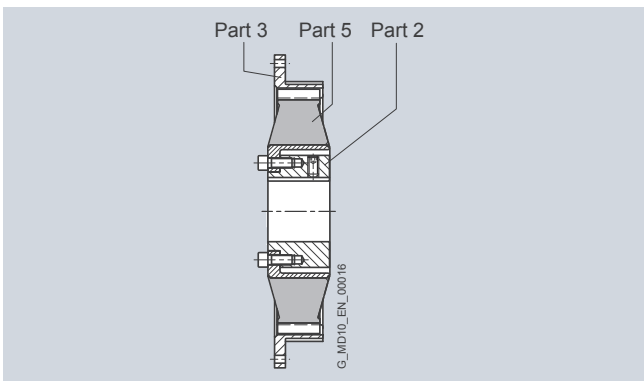

Type **ESN** – short version

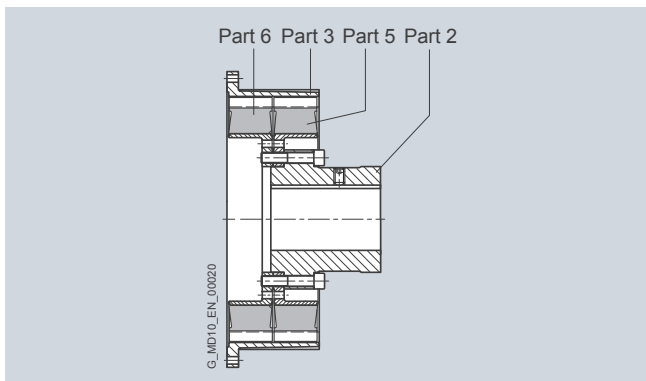

Type **ESDR**

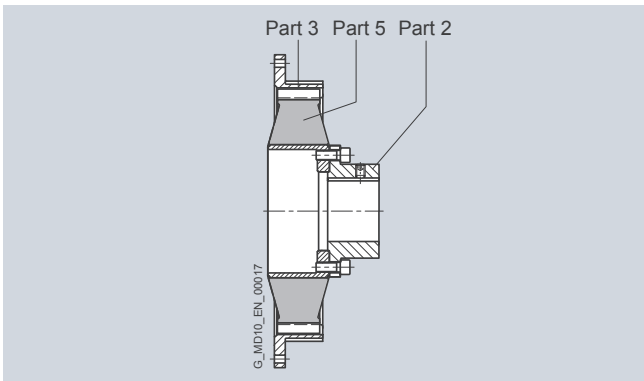

Type **ESNR**

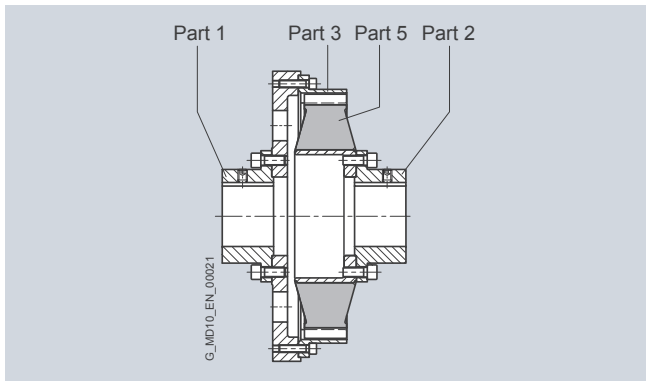

Type **ESNW**

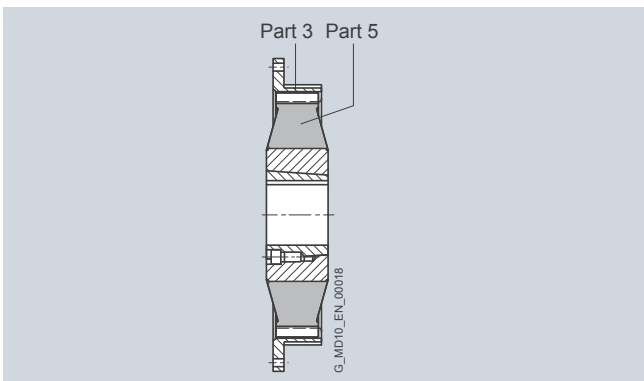

Type **EST**

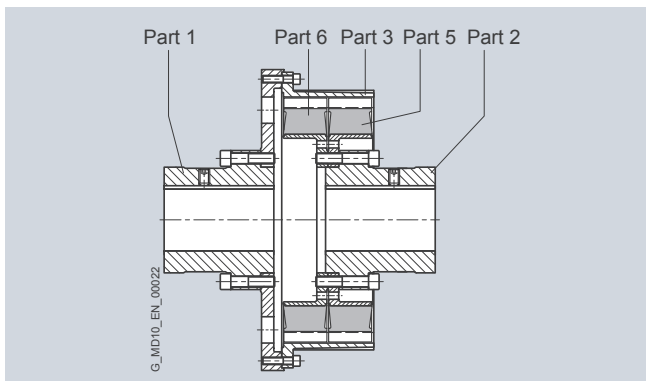

Type **ESDW**

FLENDER Standard Couplings

Highly Flexible Couplings - ELPEX-S Series

General information

Further application-related coupling types are available. Dimension sheets for and information on these are available on request.

The following versions have already been implemented a number of times:

- ELPEX-S coupling with brake drum, brake disk or flywheel mass
- ELPEX-S coupling with axial backlash limiter
- ELPEX-S coupling with adapter
- ELPEX-S coupling with bearing for mounting a cardan shaft
- ELPEX-S coupling for engaging/disengaging during standstill
- ELPEX-S coupling as part of a coupling combination
- ELPEX-S coupling with fail-safe device

Fail-safe device of ELPEX-S coupling

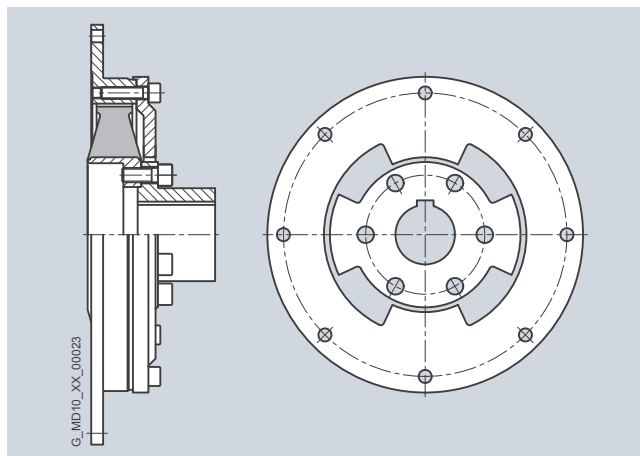

The ELPEX-S coupling can also be designed with a fail-safe device. If the rubber disk element fails, the coupling can continue operating in emergency mode for a short time. This option is frequently required e.g. in the case of marine drives.

If the rubber disk element fails, cams transmit the torque from the inner and outer parts of the fail-safe device.

In normal operation the torsion angle of the rubber disk element is smaller than the gap between the cams, so there is no metal-metal contact.

Function

The ELPEX-S coupling's transmission characteristic is determined essentially by the rubber disk element. The torque is transmitted positively between the rubber disk element and the outer flange. The outer flange can be bolted to e.g. a diesel motor or compressor flywheel.

Configuration

Coupling selection

The ELPEX-S coupling is especially suitable for rough operating environments. An application factor lower than that in catalog section 3 is therefore sufficient for all applications. In the case of machines which excite torsional vibration, FLENDER urgently recommends carrying out a torsional vibration calculation or measuring the coupling load occurring in the drive.

Coupling load in continuous operation

Application factor FB	Torque characteristic of the driven machine		
	uniform with moderate shock loads	non uniform	very rough
Torque characteristic of the driving machine			
Electric motors, hydraulic motors, gas and water turbines	1.0	1.3	1.4
Internal combustion engines	1.3	1.4	1.6

Examples of torque characteristic in driven machines:

- uniform with moderate shock loads: generators, fans, blowers
- non uniform: reciprocating compressors, mixers, conveyor systems
- very rough: crushers, excavators, presses, mills

Coupling	Rubber version	Elastomer material	Temperature T_a on the coupling									
			-40 to -30 °C	-30 to +50 °C	to 60 °C	to 70 °C	to 80 °C	to 90 °C	to 100 °C	to 110 °C	to 120 °C	
ELPEX-S	SN, NN, WN	NR	1.1	1.0	1.25	1.40	1.60					
ELPEX-S	NX	VMQ	1.1	1.0	1.0	1.0	1.0	1.1	1.25	1.4	1.6	

NR = natural-synthetic rubber mixture
VMQ = silicone rubber

Select coupling size with: $T_{KN} \geq T_N \cdot FB \cdot FT$

11

FLENDER Standard Couplings

Highly Flexible Couplings - ELPEX-S Series

General information

Coupling load under maximum and overload conditions

The maximum torque is the highest load acting on the coupling in normal operation.

Maximum torques at a frequency of up to 25 times an hour are permitted and must be lower than the maximum coupling torque. Examples of maximum torque conditions are: Starting operations, stopping operations or usual operating conditions with maximum load.

$$T_{Kmax} \geq T_{max} \cdot FT$$

Overload torques are maximum loads which occur only in combination with special, infrequent operating conditions.

Examples of overload torque conditions are: Motor short circuit, emergency stop or blocking because of component breakage. Overload torques at a frequency of once a month are permitted and must be lower than the maximum overload torque of the coupling. The overload condition may last only a short while, i.e. fractions of a second.

$$T_{KOL} \geq T_{OL} \cdot FT$$

Coupling load due to dynamic torque load

Applying the frequency factor FF, the dynamic torque load must be lower than the coupling fatigue torque.

Dynamic torque load

$$T_{KW} \geq T_W \cdot FT \cdot FF \cdot \frac{0.6}{FB - 1.0}$$

Frequency of the dynamic torque load

$f_{err} \leq 10$ Hz frequency factor FF = 1.0

Frequency of the dynamic torque load

$f_{err} > 10$ Hz frequency factor FF = $\sqrt{(f_{err}/10 \text{ Hz})}$

 Operation in potentially explosive environments is subject to the following restriction:

Operation with low fatigue load

 The fatigue torque T_{KW} must be reduced by 70 %. In these particular operating conditions the coupling satisfies the requirements of temperature class T4 D120 °C.

Operation with medium fatigue load

 The fatigue torque T_{KW} must be reduced by 50 %. In these particular operating conditions the coupling satisfies the requirements of temperature class T3 D160 °C.

Checking the maximum speed

The following must apply to all load situations: $n_{Kmax} \geq n_{max}$

The maximum speed of a size depends only on the size of the outer flange (part 3).

Checking permitted shaft misalignment and restorative forces

For all load situations, the actual shaft misalignment must be less than the permitted shaft misalignment.

Checking bore diameter, mounting geometry and coupling design

The check must be made on the basis of the dimension tables. On request, couplings with adapted geometry can be provided.

Checking shaft-hub connection

Please refer to catalog section 3 for instructions.

Checking temperature and chemically aggressive environment

The permitted coupling temperature is specified in the Temperature Factor FT table. In the case of chemically aggressive environments, please consult the manufacturer.

FLENDER Standard Couplings

Highly Flexible Couplings - ELPEX-S Series

General information

Technical data

Power ratings

Rubber dusk elements made of a natural and synthetic rubber mixture									
Type	Size	Rubber element	Rated torque	Maximum torque	Overload torque	Fatigue torque	Dynamic torsional stiffness	Motor flange	Maximum speed
			T_{KN} Nm	T_{Kmax} Nm	T_{KOL} Nm	T_{KW} Nm	C_{Tdyn} Nm/rad	SAE J620d Size	n_{max} rpm
ESN . EST	220	WN	330	660	750	165	1100	6.5	4200
		NN	360	720	900	180	1700	7.5	4200
		SN	400	800	1000	200	2500	8 10	4200 3600
ESN . EST	265	WN	500	1000	1250	250	2100	8	4200
		NN	600	1200	1800	300	3100	10	3600
		SN	700	1400	2100	350	4500	11.5	3500
ESN . EST	290	WN	800	1600	2000	400	3600	10	3600
		NN	900	1800	2700	450	5000	11.5	3500
		SN	1000	2000	3000	500	7500		
ESN . EST	320	WN	1200	2400	3000	600	8000	11.5	3500
		NN	1350	2700	3600	650	10000	14	3000
		SN	1550	3100	4200	750	13500		
ESN . EST	360	WN	1800	3600	4500	900	8500	11.5	3200
		NN	2000	4000	5400	1000	13000	14	3000
		SN	2500	5000	7500	1250	22000		
ESN . EST	420	WN	3100	6200	7700	1500	16000	14	3000
		NN	3450	6900	10000	1700	30000	16	2600
		SN	4200	8400	12600	2100	45000	18	2300
ESN . EST	465	WN	4600	9200	10000	2300	35000	14	3000
		NN	5200	10400	15600	2600	56000	16	2600
		SN	6300	12600	18900	3100	100000	18	2300
ESN .	520	WN	6200	12400	14000	3100	38000	18	2300
		NN	7000	14000	21000	3500	75000	21	2000
		SN	7800	15600	23400	3900	110000		
ESD .	520	WN	12400	24800	28000	6200	76000	18	2300
		NN	14000	28000	42000	7000	150000	21	2000
		SN	15600	31200	46800	7800	220000		
ESN .	560	WN	8000	16000	18000	4200	55000	18	2300
		NN	9000	18000	27000	4800	100000	21	2000
		SN	10000	20000	30000	5500	190000		
ESD .	560	WN	16000	32000	36000	8400	110000	18	2300
		NN	18000	36000	54000	9600	200000	21	2000
		SN	20000	40000	60000	11000	380000		
ESN .	580	WN	11000	22000	28000	5500	75000	18	2300
		NN	12500	25000	37000	6250	120000	21	2000
		SN	14000	28000	42000	7000	210000		
ESD .	580	WN	22000	44000	56000	11000	150000	21	2000
		NN	25000	50000	74000	12500	240000	24	1800
		SN	28000	56000	84000	14000	420000		
ESN .	680	WN	16000	32000	40000	8000	150000	21	2000
		NN	18000	36000	54000	9000	250000	24	1800
		SN	20000	40000	60000	10000	450000		
ESD .	680	WN	32000	64000	80000	16000	300000	21	2000
		NN	36000	72000	108000	18000	500000	24	1800
		SN	40000	80000	120000	20000	900000		
ESN .	770	WN	25000	50000	75000	12500	250000	similar to DIN 6288	1500
		NN	28000	56000	84000	14000	400000		
		SN	31500	63000	94000	15000	700000		
ESD .	770	WN	50000	100000	150000	25000	500000	similar to DIN 6288	1300
		NN	56000	112000	168000	28000	800000		
		SN	63000	126000	189000	30000	1400000		

Torsional stiffness depends on the ambient temperature and the frequency and amplitude of the torsional vibration excitation. More precise torsional stiffness and damping parameters on request.

FLENDER Standard Couplings

Highly Flexible Couplings - ELPEX-S Series

General information

Rubber disk elements made of silicone rubber

Type	Size	Rubber version	Rated torque	Maximum torque	Overload torque	Fatigue torque	Dynamic torsional stiffness for 100 % load
			T_{KN} Nm	T_{Kmax} Nm	T_{KOL} Nm	T_{KW} (10 Hz) Nm	C_{Tdyn} kNm/rad
ESN .	220	NX	200	300	400	87	1.70
ESN .	265	NX	300	450	600	133	3.10
ESN .	290	NX	500	750	1000	213	5.40
ESN .	320	NX	770	1150	1530	320	12.0
ESN .	360	NX	1200	1800	2400	480	12.7
ESN .	420	NX	2000	3000	4000	800	30.0
ESN .	465	NX	3000	4500	6000	1200	53.0
ESN .	520	NX	4100	6100	8200	1600	75.0
ESD .	520	NX	8200	12300	16400	3200	150
ESN .	560	NX	5000	7500	10000	2200	83
ESD .	560	NX	10000	15000	20000	4400	166
ESN .	580	NX	6500	9750	13000	2667	113
ESD .	580	NX	13000	19500	26000	5867	226
ESN .	680	NX	10000	15000	20000	4000	225
ESD .	680	NX	20000	30000	40000	8000	450
ESN .	770	NX	15000	22500	30000	6000	480
ESD .	770	NX	30000	45000	60000	12000	960

Torsional stiffness

The dynamic torsional stiffness of the silicone rubber elements is load-dependent and increases in proportion to the load. The values specified in the selection table represent 100 % loading. The following table shows the correction factors for different rated loads.

$$C_{Tdyn} = C_{Tdyn 100\%} \cdot FK$$

Correction factor	Load T_N / T_{KN}						
	20 %	50 %	60 %	70 %	80 %	100 %	150 %
FKC	0.42	0.57	0.64	0.72	0.8	1	1.6

Torsional stiffness also depends on the ambient temperature and the frequency and amplitude of the torsional vibration excitation. More precise torsional stiffness and damping parameters on request.

Damping coefficient of the rubber versions

Rubber version	Hardness Shore A	Damping coefficient ψ
WN	50° ... 55°	0.80
NN	60° ... 65°	1.15
SN	70° ... 75°	1.25
NX	55° ... 65°	1.15

Size	Assembly ΔS mm	Permitted shaft misalignment at $n = 1500$ rpm		
		Axial ΔK_a mm	Radial ΔK_r mm	Angle ΔK_w degrees
220	1.3	0.2	1.2	0.5
265	1.3	0.2	1.2	0.5
290	1.5	0.2	1.2	0.5
320	1.5	0.2	1.2	0.5
360	1.5	0.2	1.2	0.5
420	1.5	0.3	1.3	0.4
465	1.7	0.3	1.3	0.4
520	1.7	0.3	1.4	0.4
560	1.7	0.3	1.4	0.4
580	1.8	0.4	1.5	0.3
680	1.8	0.4	1.5	0.3
770	2.0	0.5	1.5	0.3

For fitting, a maximum gap dimension of $S_{max} = S + \Delta S$ and a minimum gap dimension of $S_{min} = S - \Delta S$ are permitted.

Permitted shaft misalignment

The permitted shaft misalignment depends on the operating speed. As the speed increases, lower shaft misalignment values are permitted. The following table shows the correction factors for different speeds.

The maximum speed for the respective coupling size and type must be noted!

$$\Delta K_{perm} = \Delta K_{1500} \cdot FKV$$

Correction factor FKV	Speed in rpm			
	500	1000	1500	3000
FKV	1.20	1.10	1.0	0.70

FLENDER Standard Couplings

Highly Flexible Couplings - ELPEX-S Series

General information

Variants of the outer flange

The outer flange of sizes 220 to 680 is designed to fit the connection dimensions of the SAE J620d standard. The centering depth on the connection flange of the machine should be between 4 mm and 6.4 mm as a maximum.

Type	Size	Flange connection size	Figure
ESN	220	6.5	1
ESN	220	7.5	2
ESN, ESNR	265	8	
ESN, ESNR	360	11.5	
ESN, ESNR	465	14	
ESN, ESNR	560	18	
ESN, ESNR	580	18	
ESN, ESNR	680	21	
ESN	220	8, 10	3
ESN, ESNR	265	10, 11.5	
ESN, ESNR	290	All	
ESN, ESNR	320	All	
ESN, ESNR	360	14	
ESN, ESNR	420	All	
ESN, ESNR	465	16, 18	
ESN, ESNR	520	All	
ESN, ESNR	560	21	
ESN, ESNR	580	21	
ESN, ESNR	680	24	
ESD, ESDR	520	All	4
ESD, ESDR	560	All	
ESD, ESDR	580	All	
ESD, ESDR	680	21	5
ESD, ESDR	680	24	6
ESD, ESDR	770	All	

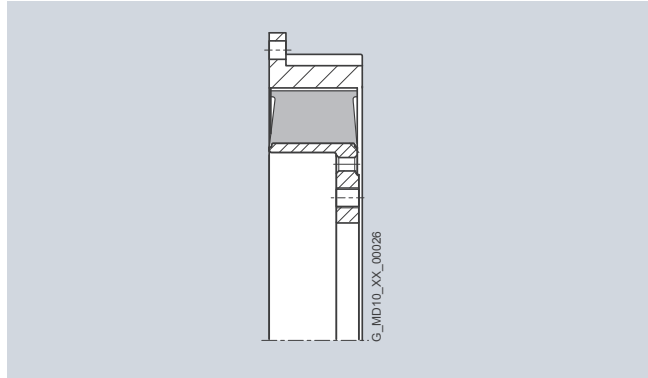

Figure 3

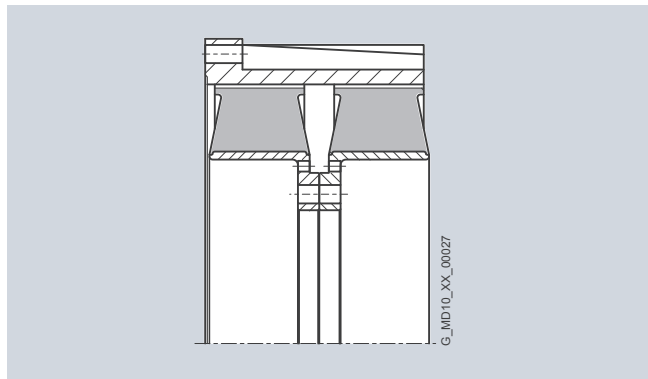

Figure 4

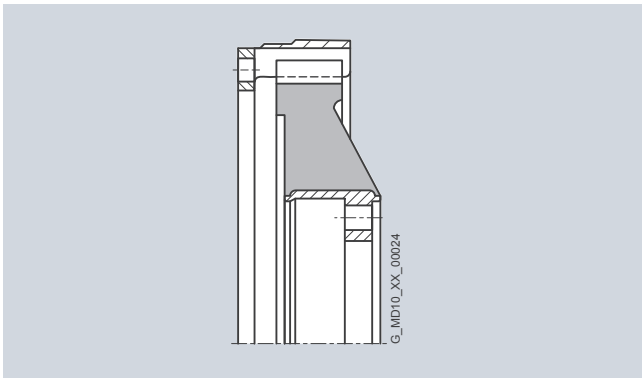

Figure 1

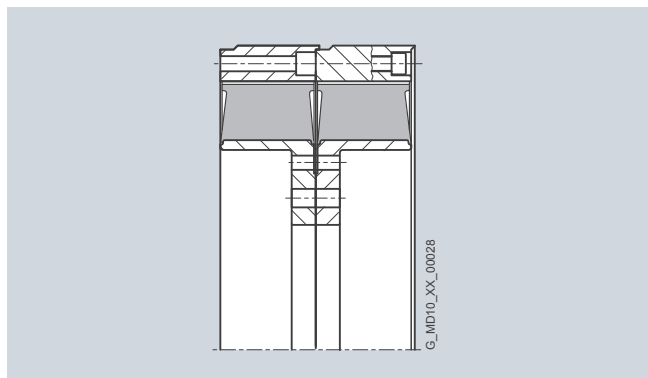

Figure 5

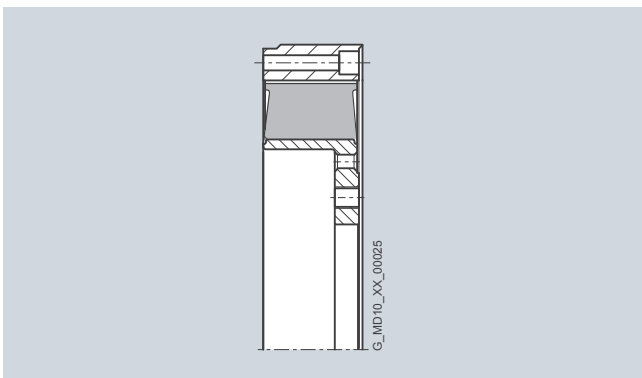

Figure 2

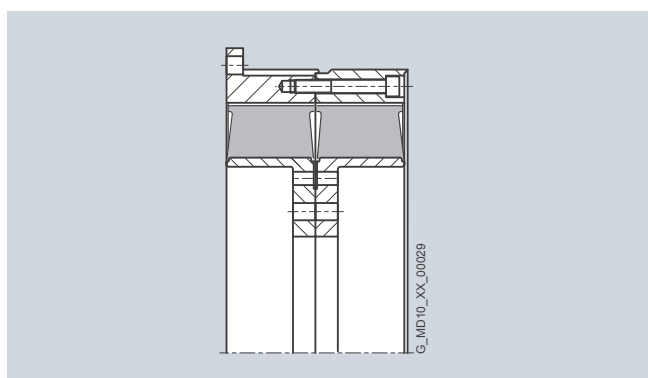
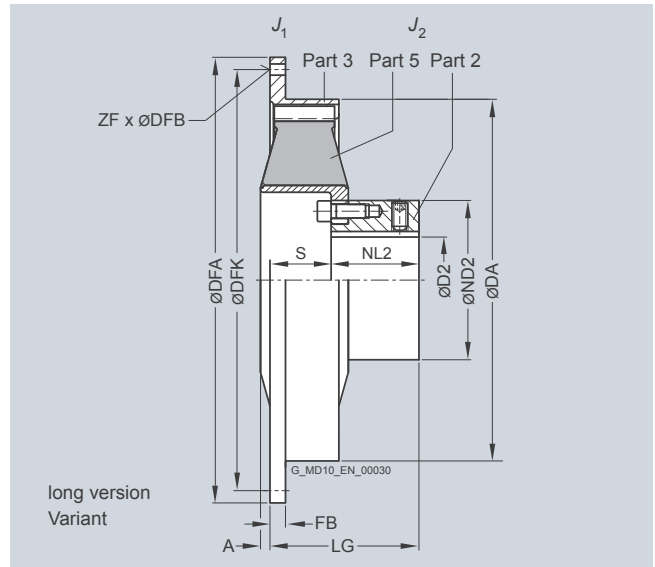
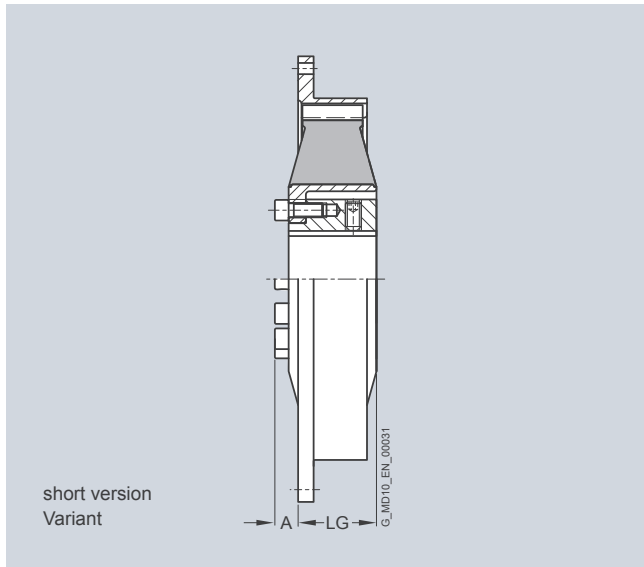

Figure 6

FLENDER Standard Couplings Highly Flexible Couplings - ELPEX-S Series

Type ESN

Selection and ordering data



The rubber disk element cannot be dismantled until the machines have been moved.

Size	Dimensions in mm						Flange connection dimensions								Mass moment of inertia		Product code with order codes M.. for bore diameter ØD2 and tolerances (product code without -Z) - selection in catalog part 3	Weight <i>m</i> kg	
	D2 Keyway DIN 6885 max.	DA	ND2	NL2	A	LG	SAE	DFA	DFK	FB	ZF	DFB	<i>J</i> ₁	<i>J</i> ₂					
220	60	222	98	54	-	-	0	49	103	6.5	215.9	200.0	8	6	8.5	0.008	0.01	2LC0220-0A B 0 - - AAO	5.8
							40	94	7.5	241.3	222.3	33	8	8.5	0.011		2LC0220-0A B 0 - - BAO	6.1	
							40	94	8	263.5	244.5	8	6	10.5	0.011		2LC0220-0A B 0 - - CAO	6.4	
							40	94	10	314.3	295.3	8	8	10.5	0.017		2LC0220-0A B 0 - - DAO	6.9	
265	65	263	118	65	15	74	3	39	104	8	263.5	244.5	38	6	10.5	0.011	0.022	2LC0220-1A 0 0 - - CAO	6.6
							10	314.3	295.3	10	8	0.017		2LC0220-1A 0 0 - - DAO	6.9				
							11.5	352.4	333.4	10	8	0.024		2LC0220-1A 0 0 - - EAO	7.2				
290	65	290	118	70	19	58	6	36	106	10	314.3	295.3	16	8	10.5	0.026	0.026	2LC0220-2A 0 0 - - DAO	9.2
							11.5	352.4	333.4	16	8	0.036		2LC0220-2A 0 0 - - EAO	10.5				
320	80	318	140	87	20	91	8	65	152	11.5	352.4	333.4	16	8	10.5	0.062	0.061	2LC0220-3A 0 0 - - EAO	19
							14	466.7	438.2	16	8	13	0.18		2LC0220-3A 0 0 - - FAO	20.5			
360	90	358	160	105	29	92	13	56	161	11.5	352.4	333.4	65	8	10.5	0.065	0.13	2LC0220-4A 0 0 - - EAO	24.5
							14	466.7	438.2	15	8	13	0.18		2LC0220-4A 0 0 - - FAO	27.5			
420	100	420	185	102	26	92	10	72	174	14	466.7	438.2	18	8	13	0.22	0.32	2LC0220-5A 0 0 - - FAO	36
							16	517.5	489.0	18	8	13	0.32		2LC0220-5A 0 0 - - GAO	38			
							18	571.5	542.9	18	6	17	0.47		2LC0220-5A 0 0 - - HAO	40			
465	120	465	222	125	0	92	33	39	164	14	466.7	438.2	85	8	13	0.31	0.58	2LC0220-6A 0 0 - - FAO	56
							16	517.5	489.0	27	8	13	0.41		2LC0220-6A 0 0 - - GAO	57			
							18	571.5	542.9	18	6	17	0.52		2LC0220-6A 0 0 - - HAO	61			
520	165	514	250	142	16	159	0	83	225	18	571.5	542.9	18	12	17	0.48	0.93	2LC0220-7A 0 0 - - HAO	55
							21	673.1	641.4	18	12	0.95		2LC0220-7A 0 0 - - JAO	60				
560	200	560	320	140	25	136	9	83	223	18	571.5	542.9	35	12	17	0.85	1.2	2LC0220-8A 0 0 - - HAO	69
							21	673.1	641.4	35	12	1.8		2LC0220-8A 0 0 - - JAO	78				
580	200	580	316	200	23	215	3	100	300	18	571.5	542.9	104	12	17	0.77	1.8	2LC0221-0A 0 0 - - HAO	100
							21	673.1	641.4	26	12	1.2		2LC0221-0A 0 0 - - JAO	105				
680	220	682	380	210	24	232	0	102	312	21	673.1	641.4	85	12	17	4.1	5.3	2LC0221-1A 0 0 - - HAO	205
							24	733.4	692.2	20	12	21	5.3		2LC0221-1A 0 0 - - KAO	215			

Weight and mass moments of inertia apply to maximum bore diameters.

Ordering example:

ELPEX-S ESN coupling, size 520, WN rubber element, hub with bore ØD2 = 150H7 mm, with keyway to DIN 6885 and set screw, outer flange to SAE J620d size 21.

Product code:

short version: **2LC0220-7AA09-1JAO M1W**

long version: **2LC0220-7AB09-1JAO M1W**